

Simulation of a heated Tool System for Jet Electrochemical Machining

Matthias Hackert^{*1}, Andreas Schubert^{1,2}, Gunnar Meichsner²

¹Chemnitz University of Technology, Chair Micromanufacturing Technology

*09107 Chemnitz, Germany, matthias.hackert@mb.tu-chemnitz.de

²Fraunhofer Institute for Machine Tools and Forming Technology

Abstract: Jet Electrochemical Machining (Jet-ECM) is an unconventional procedure using localized anodic dissolution for micromachining [1, 2, 3, 4]. An increasing of the electrolyte temperature e. g. from 20°C to 35°C will lead to an increase of the electrical conductivity of the electrolyte by about 30 % and to a reduction of the dynamic viscosity of the electrolyte by about 25 %. Both will improve the process. Therefore a Jet-ECM tool system with integrated heating cartridge was developed at Chemnitz UT and COMSOL Multiphysics was used to simulate the temperature distribution in the tool system for different heating powers.

The model was created by help of importing the CAD data of the tool system into COMSOL and consists a coupling of fluid flow and convection and conduction. The results of the simulation will perspectively help to design the experimental investigations in high temperature Jet Electrochemical Machining

Keywords: Jet Electrochemical Machining, localized anodic dissolution, closed electrolytic free jet, Electrochemical Micromachining

1 Introduction

The basic principle of all applications of ECM in production engineering is an anodic dissolution of metallic work pieces at their interface to a liquid ion conductor, called electrolyte, under the influence of electric charge transport. Electrochemical Machining with a closed electrolytic free jet (Jet-ECM) is an innovative form of electrochemical removal, which applies high current densities connected with a high degree of local removal, a high localization of erosion and a high surface quality.

The potential of Jet-ECM as microproduction technique is currently investigated at the Chair Micromanufacturing Technology at

Chemnitz University of Technology. The research work concentrates on several emphases.

First main focus is machining of micro geometries by Jet-EC milling. As example figure 1 shows a detail of a cavity with a total length of 4521 μm which was machined 10 times using 300 $\mu\text{m}/\text{min}$ nozzle movement velocity. That means a total processing time of 150,7s. The mean current density in the jet at the beginning of machining was about 1000 A/cm^2 . The cavity is about 180 μm deep and 190 μm wide. The roughness parameters in the cavity are $R_z \approx 1 \mu\text{m}$ and $R_a \approx 0,1 \mu\text{m}$.

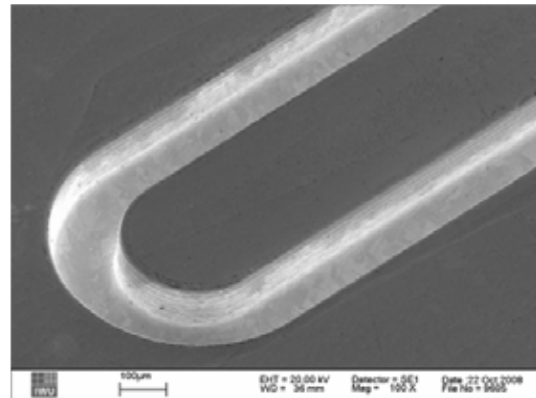

Figure 1: Applying Jet-ECM produced microcavity in stainless steel

As second emphasis the procedure is inserted for the manufacturing of microstructured surfaces. Figure 2 shows as example a detail of a microstructured surface which was machined with 100 Jet-ECM point erosions. The generated calottes, which have a processing time of 0,2 seconds, are about 15 μm deep and 200 μm in diameter. The roughness parameters in the calottes are $R_z \approx 1 \mu\text{m}$ and $R_a \approx 0,1 \mu\text{m}$.

The third main focus is the simulation of electrochemical machining, in particular the Jet-ECM [5, 6, 7]. Not at least also other procedures for micro machining are simulated with COMSOL Multiphysics [8].

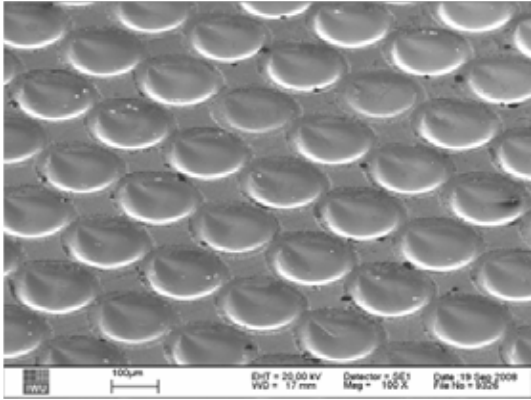

Figure 2: Applying Jet-ECM produced microstructured surface in stainless steel

To be able to investigate the influence of the electrolyte temperature on the Jet-EC Machining result a tool system with integrated heating cartridge was simulated and realized. The model, which is illustrated in figure 3, was created by help of importing the CAD data of the tool system into COMSOL.

A photo of the realized tool system is shown in figure 4. To realize the tempering a high-capacity pipe cartridge by the type RPT 2,2x4,3 of the company Türk+Hillinger GmbH is used in connection with a temperature regulator of the type 2204E of the company Eurotherm Germany GmbH.

All performed simulations consists of a coupling of fluid flow and convection and conduction, whereas the temperature of the heating cartridge was varied to investigate the influence of different heating rates.

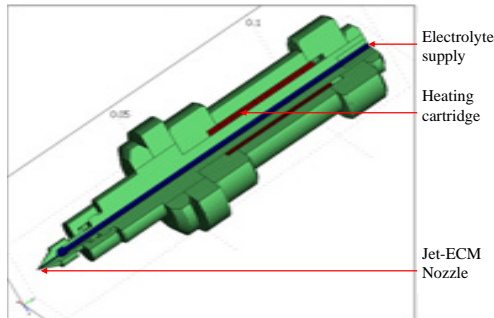

Figure 3: Scheme of the model

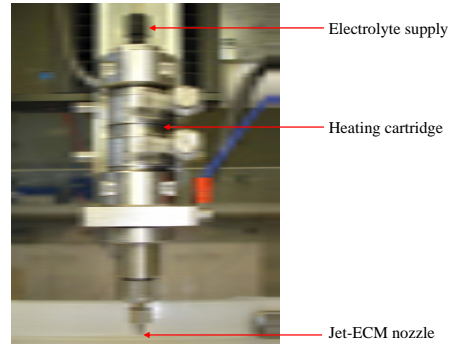

Figure 4: Photo of the realized tool system

2 Geometry and Mesh

The geometry of the model was generate by importing the CAD Data of the tool system which was designed in Autodesk Inventor. For simplicity a rotational symmetric model was created. Figure 5 shows the geometry with the mesh and the axis of symmetry.

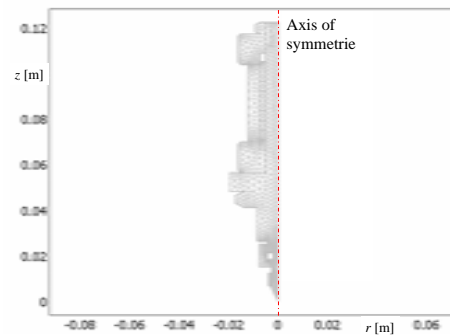

Figure 5: Geometry and mesh of the model

The mesh was generated with the standard meshing parameters of COMSOL. It consists of 3432 elements.

3 Subdomains

For all subdomain definitions the COMSOL Material Library was used. The model consists of three different groups of subdomains which are obvious in figure 3. All green subdomains in figure 3 are defined as steel 1.6565 with a starting temperature of 20°C. The heating cartridge which is red in figure 3 is defined as 1.6565 too, but with the heating temperature T_{heat} .

Blue in figure 3 the electrolyte is marked which was defined as water. In this subdomain heat transfer is defined to be done by the velocity field of the incompressible Navier-Stokes flow. The Navier-Stokes flow is only active in the electrolyte subdomain.

4 Boundaries

All inner boundaries are defined as continuity and for simplicity all outer boundaries are defined to be thermal insulation. On the top of the tool system the electrolyte supply is connected. That means in the simulation here we have an entrance velocity of 0,034 m/s and room temperature. That means a flow rate of 10 ml/min which is typical for Jet-ECM. On the bottom of the electrolyte subdomain the jet leaves the nozzle with the boundary conditions pressure $1 \cdot 10^5$ Pa and convective flux.

5 Results

Figure 6 shows the velocity field of the electrolyte in the nozzle as result of the incompressible Navier-Stokes application mode. The electrolyte is accelerated up to 28,684 m/s and has a mean velocity of 21,22 m/s. This velocity field is used to calculate the heat transport through convective flux in the convection and conduction application mode.

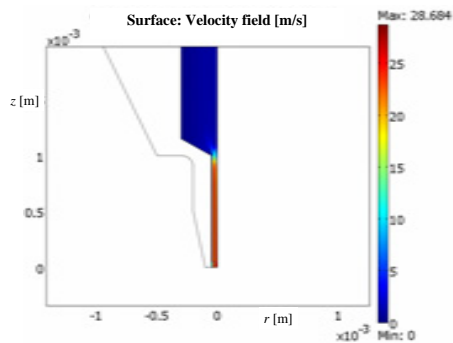

Figure 6: Velocity field in the Jet-ECM nozzle

To analyze the function of the heated tool system simulations were done for the heating temperatures 30°C, 40°C, 50°C, 60°C and 70°C. As example result figure 7 shows the temperature distribution for $T_{\text{heat}} = 50^\circ\text{C}$. As expected the highest temperature can be found in the area of the heating cartridge.

The electrolyte temperature increases systematically from the entrance to the Jet-ECM nozzle.

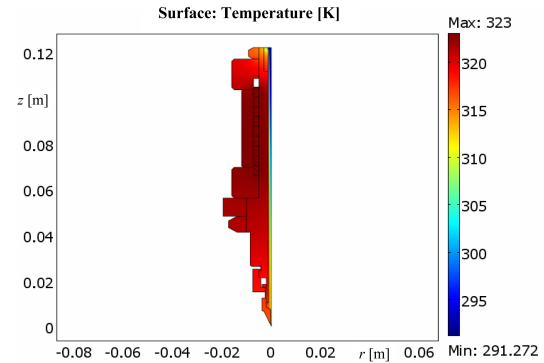

Figure 7: Temperature distribution in the tool system for $T_{\text{heat}} = 50^\circ\text{C}$

To get a closer look on the temperature distribution in the Jet-ECM nozzle figure 8 shows this detail enlarged. It can be found that the electrolyte leaves the nozzle with a mean temperature of approximate 39°C.

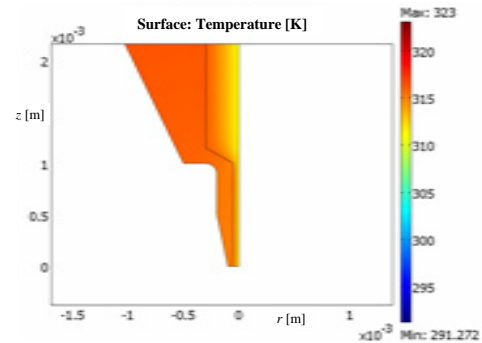

Figure 8: Temperature distribution in the Jet-ECM nozzle for $T_{\text{heat}} = 50^\circ\text{C}$

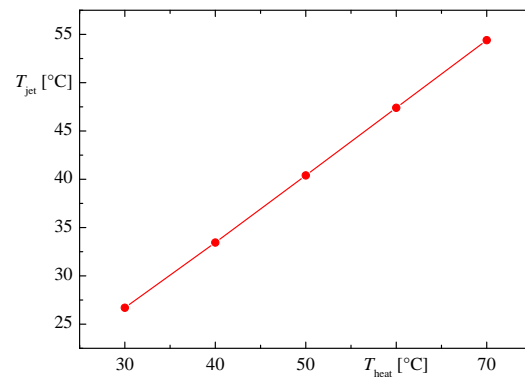

Figure 9: Temperature of the jet as function of the heating temperature

The correlation of the temperature of the jet as function of the heating temperature is shown in figure 9. Deductive the simulated jet temperature is a linear function of the heating temperature.

6 Conclusions

In this study a Jet-ECM tool system with integrated heating cartridge which was developed at Chemnitz UT was simulated with COMSOL Multiphysics. The temperature distribution in the tool system was analyzed for different heating powers. In this simplified model which is the first approximation for the tool system a linear function for the jet temperature results.

Next steps will be first experimental investigations e. g. on the temperature of the jet. Furthermore the influence of the temperature on the processing results will be studied.

7 Acknowledgment

The authors thanks the German Research Foundation for the financial support.

References

- [1] W. Natsu, T. Ikeda, M. Kunieda. Generating complicated surface with electrolyte jet machining. *Precision Engineering*, 31:33–39, 2007.
- [2] M. Hackert, G. Meichsner, A. Schubert. Fast Micro Structuring with Electrolyte Jet Machining. *In: Proceedings of Fourth International Symposium on Electrochemical Machining Technology*, 1:123–128, 2007. ISBN 978-3-00-022770-7.
- [3] M. Hackert, G. Meichsner, A. Schubert. Generating Micro Geometries with Air assisted Jet Electrochemical Machining. *In: Proceedings of the euspen 10th Anniversary International Conference*, 2:420–424, 2008. ISBN 978-0-9553082-5-3.
- [4] M. Hackert, G. Meichsner, A. Schubert. Generating plane and microstructured surfaces applying Jet Electrochemical Machining. *In: Proceedings of Fifth International Symposium on Electrochemical Machining Technology*, 2009. in print.
- [5] A. Schubert, M. Hackert. Blick in den Elektrolytstrahl. *Mikroproduktion*, 4:44–47, 2008.
- [6] M. Hackert, G. Meichsner, A. Schubert. Simulation of the Shape of Micro Geometries generated with Jet Electrochemical Machining. *Proceedings of the second European COMSOL Conference*, 2008. ISBN 978-0-9766792-3-3.
- [7] M. Hackert, G. Meichsner, A. Schubert. Simulation of a heated Tool System for Jet Electrochemical Machining. *Proceedings of the third European COMSOL Conference*, 2009. in print.
- [8] A. Schubert, R. Pohl, M. Hackert. Simulation of a modular Tool System for Micro Impact Extrusion. *Proceedings of the third European COMSOL Conference*, 2009. in print.